

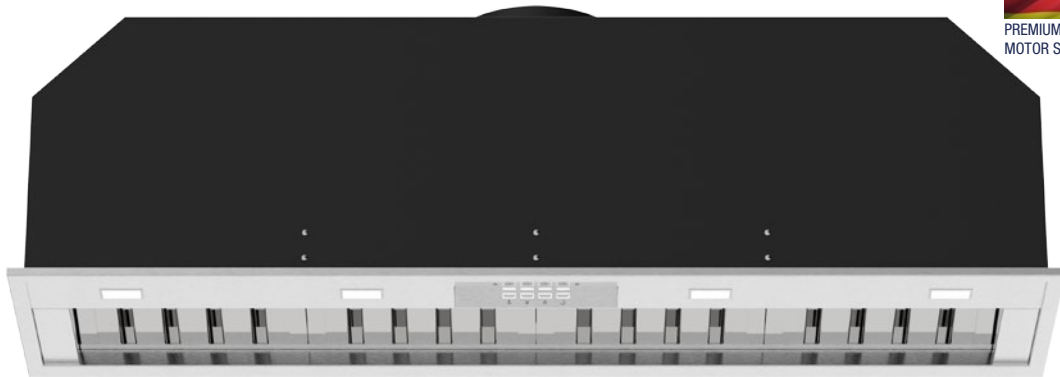

PROUDLY AUSTRALIAN OWNED
DESIGNED & ASSEMBLED IN MELBOURNE



PREMIUM GERMAN MADE
MOTOR SYSTEMS



- Model Number** X3M12S
- Hood Mounting** Built In (Undermount) - Flush or Proud Install
- Cooking Coverage** Suits 100cm - 120cm Cooking Surfaces
- Filtration** S-Flow Baffle Filters 4x (H-25) - Dishwasher Safe
- Lighting** LED 4x (Warm White 1.0W) - Front Panel
- Finish** **AISI304 1.2mm** Food Grade Stainless Steel
- Controls** LED Backlit 4 Button *mastermind* Electronic Control with LED Speed Indicator
- Speed Settings** 3 Speed + Boost Mode
- Timer Function** Programmable Timer (10min Increments)
Auto fan shut off after 2-hours of inactivity
- Outlet** Top or Back Duct Outlet
- Ducting (Remote)** Dia. 200mm Acoustic Flexi Ducting - Five (5) Meter Length (Supplied)
- Ducting (On Board)** Optional On Board Motor Ducting Kits Available
Ultra Motor - Dia. 200mm (Recommended)
Power Motor - Dia. 150mm (Recommended)
- Hood Width** 1160mm
- Hood Depth** 280mm
- Hood Height** 330mm (Top Duct Outlet - Plus 25mm)
- Installation Height** 700 - 750mm* (Recommended)
600mm* (Minimum)
* Clearance above the highest point of the cooktop to the underside of hood

Your Hood. Your Colour. Your Way.

Available Finishes (Stainless Steel Finish Standard)

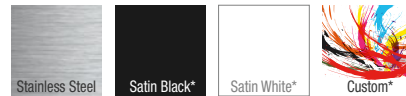

Dimensioned Drawing

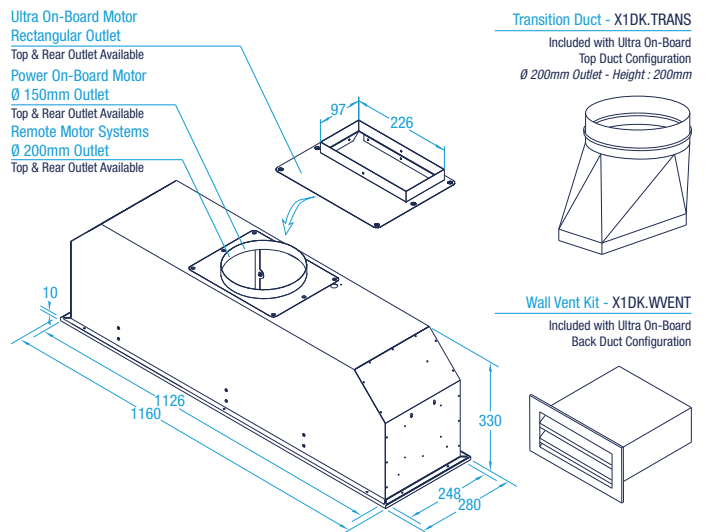

Whispair Endurance Warranty



Filtration Zone



Available Models - Select Your Motor Solution & Optional Finish

On Board

X3M12S5.OP (T / B)	Power 1,020m ³ /hr (Top or Back Ducted)	SPL: 53.9dB(A) In
X3M12S6.OU (T / B)	Ultra 1,680m ³ /hr (Top or Back Ducted)	SPL: 56.5dB(A) In

Remote External (Roof or Wall Mounted)

X3M12S5.EL	Lite 800m ³ /hr	SPL: 39.3dB(A) In / 52.7dB(A) Out
X3M12S5.EP	Pro 1,140m ³ /hr	SPL: 49.6dB(A) In / 58.5dB(A) Out
X3M12S5.EPP	Pro Plus 2,010m ³ /hr	SPL: 56.6dB(A) In / 62.8dB(A) Out

Remote Inline (Through Wall or Eave)

X3M12S5.IL	Lite 800m ³ /hr	SPL: 39.3dB(A) In / 52.7dB(A) Out
X3M12S5.IP	Pro 1,140m ³ /hr	SPL: 49.6dB(A) In / 58.5dB(A) Out

*Your Hood. Your Colour. Your Way. (Optional Undermount Finish)**

X1P3.BL	Paint Finish - Satin Black
X1P3.WH	Paint Finish - Satin White
X1P3.CUS	Paint Finish - Custom Colour

*Additional charges apply

SPL - Nominal Sound Pressure Level on Boost (Max) Speed